

120" Steel Beaded Apron Conveyor Belt

Fluent Steel Apron Pan Conveyor Belts are most commonly used to convey large, heavy, abrupt objects in mass volume. These are typically the strongest belts on the market. They are used for materials such as scrap metal (ferrous/non-ferrous), automotive, C&D, MSW, bio-fuel, e-waste, slag, and more. These belts have a much longer life cycle versus rubber or PVC combo conveyor belts and be used in wet, dry and high-temp environments. The load area for this belt is engineered and manufactured to withstand heavy repetitive impacts. The Fluent Conveyor steel apron pan belts can be engineered and manufactured for any width between 36" and 120".

Common Application Usages

- Scrap Metal
- Automotive
- Agricultural
- Bio-Fuel
- MSW
- Single Stream
- Construction & Demolition
- Hot & Abrasive Materials

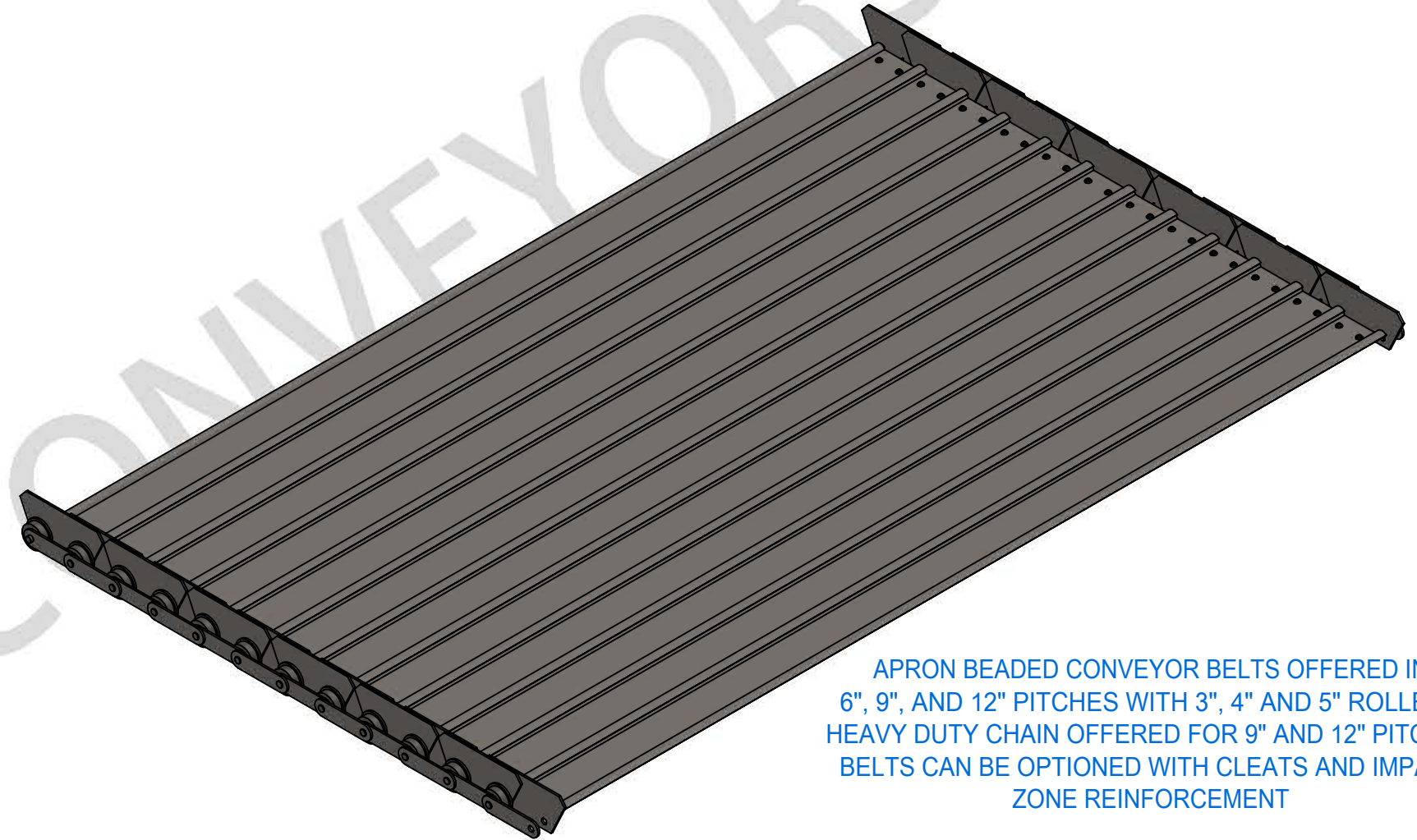
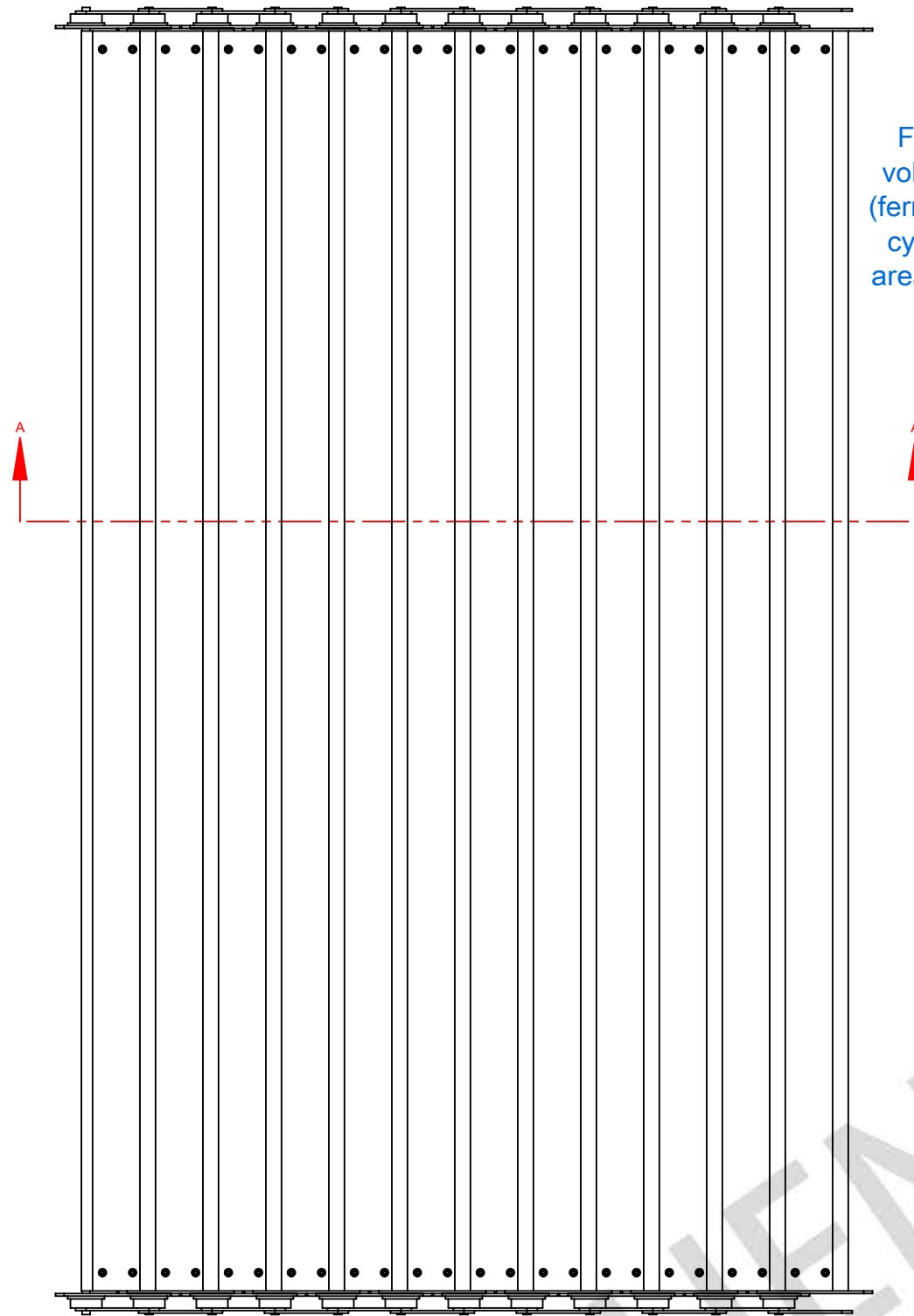

APRON BEADED CONVEYOR BELTS OFFERED IN 6", 9", AND 12" PITCHES WITH 3", 4" AND 5" ROLLERS
HEAVY DUTY CHAIN OFFERED FOR 9" AND 12" PITCHES
BELTS CAN BE OPTIONED WITH CLEATS AND IMPACT ZONE REINFORCEMENT

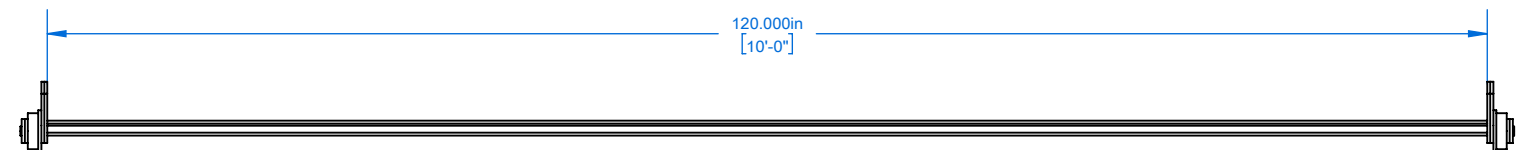
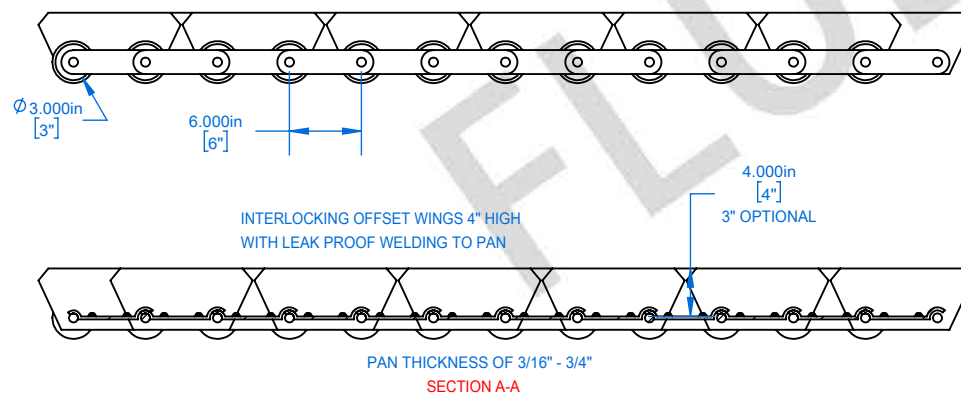

Fluent Conveyors can provide replacement belts for conveyors manufactured by but not limited to the following manufactures: Hustler Conveyors, Krause, CP Manufacturing, Green Machine, Bulk Handling Systems (BHS), Summit, Titan, Mayfran, Machinex and more.