

48" PVC/Rubber Chevron Conveyor Belt

Fluent Conveyor Chevron Cleated Conveyor Belts are most commonly used to convey lighter weight materials such as wood chips, sand and gravel, grains, minerals, cardboard, plastics, paper, fines, ONP, and more. These belts are typically found on both slider bed conveyors and trough idler conveyors. These belts are consumable products and the shelf life depends on the end user and the material type. The chevron pattern comes in a few different designs such as: open chevron, close chevron, herringbone, u-shaped, cleated top, mini-cleated top, steep climb and multi-chevron. Chevron belts are in both rubber and PVC and can support cleat sizes from 1/8" up to 2". Optional integrally molded and hot vulcanized.

Common Application Usages

- Scrap Metal
- Automotive
- Agricultural
- Bio-Fuel
- MSW
- Single Stream
- Construction & Demolition
- Hot & Abrasive Materials

Options:

- Cleats
- Integrally molded or hot vulcanized
- Wide variety of patterns

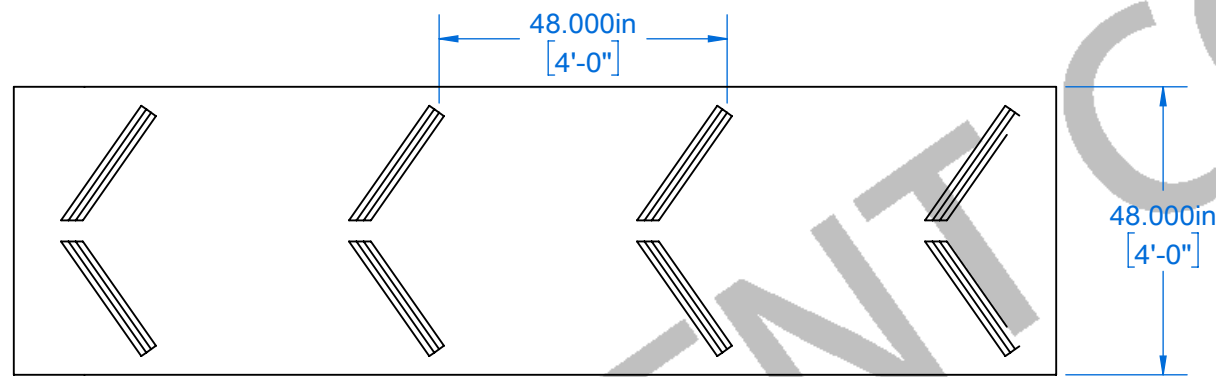

Chevron Slider Bed Belts offered with 3" and 4" cleats set at 24", 36", 48" intervals. These patterns can be customized to best suit your material handling needs.

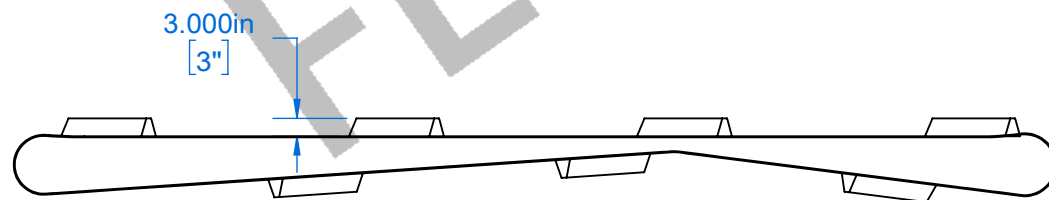

Fluent Conveyors can provide replacement belts for conveyors manufactured by but not limited to the following manufactures: Hustler Conveyors, Krause, CP Manufacturing, Green Machine, Bulk Handling Systems (BHS), Summit, Titan, Mayfran, Machinex and more.