

FLUENT 60 INCH SLIDER BED CONVEYOR

Fluent 60 Inch SB Series of conveyors are commonly used as a double sided pre-sort conveyors in MRFs as well as infeed conveyors for horizontal balers, single ram auto-tie balers & two ram balers from leading manufacturers like: Harris, International Baler, American Baler, Balemaster, Marathon, IPS, G-Baler, Sierra, Maren and more. The 60" version of slider bed is best used when conveying higher volumes of larger materials such as scrap, plastics, textiles, wood, paper, shredded materials, single stream, C&D, e-waste, OCC, ONP and also works well when paired with magnets, optical sorters, screens & eddy currents.

The 60" slider bed conveyor can extend up to lengths exceeding 150 feet and run at speeds at over 200 feet per minute. Depending on the materials being conveyed, the 60 inch slider bed conveyor can be combined a wide variety of belting options including: PVC, rough top, rubber, cleated, chevron, MOR, high temp as well as have optional return rollers and heavy duty frames. These conveyors come standard with all the proper safety equipment, pulleys, supports, installation manuals and can be combined with accessories:

hoppers (loading and discharge), pull cords, pit plates, controls, full enclosures, bottom guarding etc.

*This size of slider bed can be also be found feeding shredders, granulators, pulpers, compactor etc.

Common Application Usages

- OCC
- ONP
- PET
- HDPE
- C&D
- Textiles
- 3-7 Plastics
- Scrap (Ferrous & Non Ferrous)
- Shreds (Paper, Plastics, Rubber, Scrap)

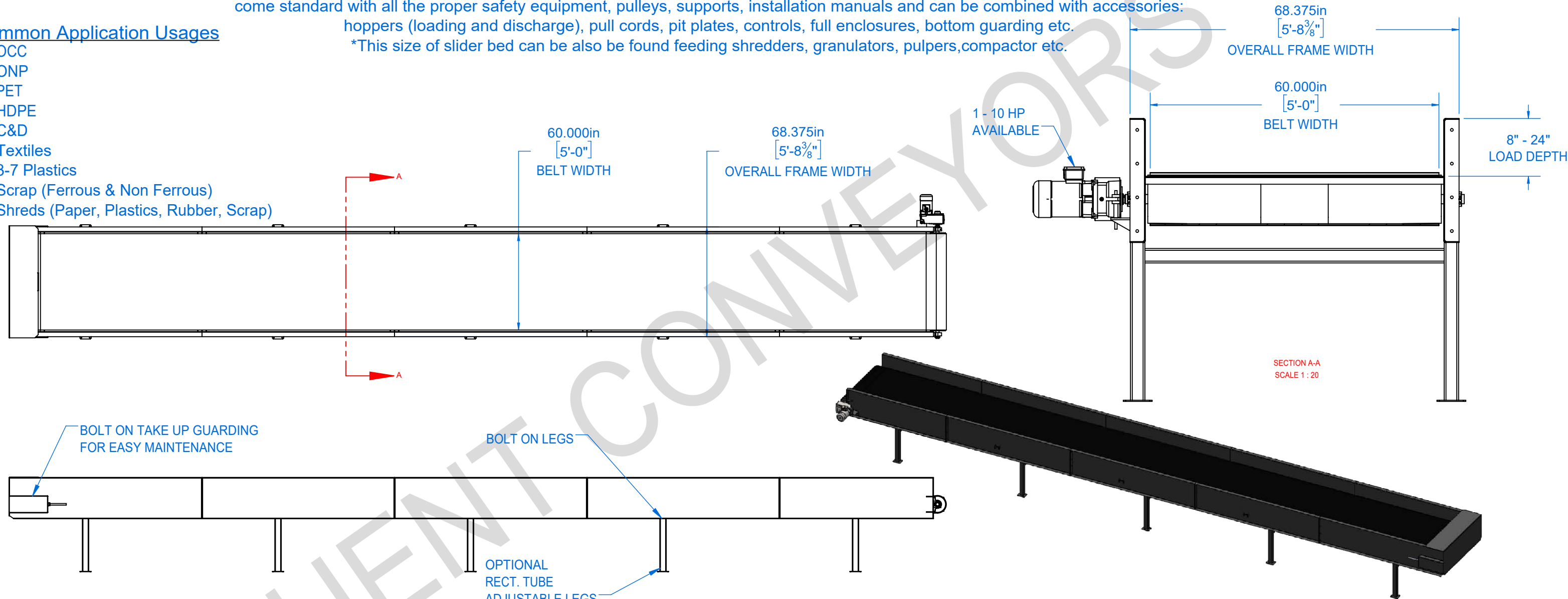

Fluent Conveyors is a premier engineering and manufacturing company headquartered in the Rocky Mountain Region with over 50+ years of combined conveyor engineering and manufacturing experience. Since Fluent's inception, dealers have integrated Fluent Conveyors and replaced conveyors from manufacturers like: Hustler Conveyors, Krause, CP Manufacturing, Green Machine, Bulk Handling Systems (BHS), Summit, Tuffman, Mayfran, Machinex and more.



PROPRIETARY AND CONFIDENTIAL
THE INFORMATION CONTAINED IN THIS DRAWING IS THE SOLE PROPERTY OF FLUENT CONVEYORS. ANY REPRODUCTION IN PART OR AS A WHOLE WITHOUT THE WRITTEN PERMISSION OF FLUENT CONVEYORS IS PROHIBITED.

UNLESS OTHERWISE SPECIFIED:		NAME	DATE
DIMENSIONS ARE IN INCHES		DRAWN	
TOLERANCES:		CHECKED	
FRACTIONAL ± 1/16"		ENG APPR.	
ANGULAR: MACH ± .5 BEND ± .5		MFG APPR.	
TWO PLACE DECIMAL ± .06		Q.A.	
THREE PLACE DECIMAL ± .062		COMMENTS:	
INTERPRET GEOMETRIC TOLERANCING PER:			
MATERIAL			
FINISH			
DO NOT SCALE DRAWING			
TITLE: FLUENT 60 INCH SLIDER BED CONVEYOR			
SIZE	PART #	REV	
B			
SCALE: 1:60		WEIGHT: 5695	SHEET 1 OF 1